



BULL624ESA



COMMERCIAL USE

control unit with built-in encoder and receiver personalised release key



up to 600 kg



BENINCA

100% Made in Italy



CONTROL UNITS:

BULL624ESA — CP.B24ESA

BULL624ESA.S — CP.B24ESA



24 Vdc | intensive use

- 24 Vdc geared motor for intensive use, with built-in control unit, ESA SYSTEM and encoder
- The encoder device ensures maximum safety and precision in the gate moving phases
- Amperometric sensor obstacle detection system to prevent crushing
- Battery back up system ready
- Metal release lever
- Version with magnetic limit switches available (BULL624ESA.S)



Raised foundation plate included. Height 34 mm. Floor fixing distance 353x117 mm, no. 4 Ø 11 mm, motor fixing distance 300x75 mm n.4 M8.

www.beninca.com

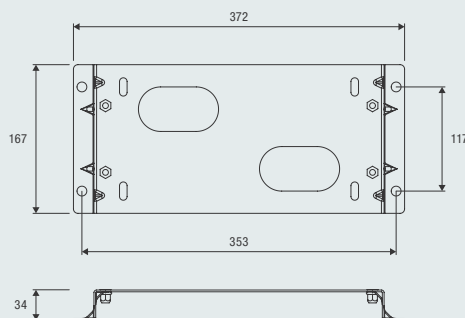
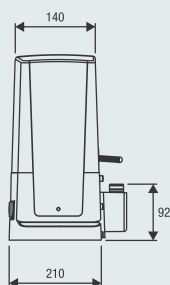
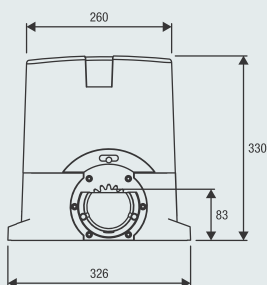

BENINCA

COMPLETE KITS

	MOTOR	PHOTOCELLS	FLASHING LIGHT	SELECTOR	TRANSMITTER
KBULL624	1x BULL624ESA	1x PUPILLA.R	1x LAMPI24.LED	1x TOKEY	1x TO.GO2VA



RI.M4F

M4 rack, to weld or attach with screws, 30x12x1000 mm slotted and galvanised. Supplied with M6 metric screws and threaded spacers.
Package of 4 pcs.



RI.M4Z

M4 galvanised rack to weld 22x22x2000 mm.
Package of 2 pcs.

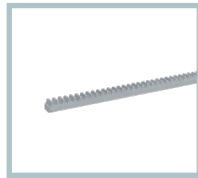

RI.M4ZF

Galvanised slotted M4 rack 22x22x2010 mm for fastening to the side with the teeth. Supplied with M6 screws.
Package of 1 pc.



RI.M4P

Nylon rack with steel core, to attach with screws, M4, 28x40x1000 mm. Slotted, provided with self-drilling screws.
Package of 10 pcs.



BULL.P3

Raised foundation plate. Height 34 mm. Floor fixing distance 260x117 mm, no. 4 Ø 11 mm, motor fixing distance 300x75 mm n.4 M8.



SB.BULL8.F

Externally fitted anti-intrusion cable unlock device (L=4.5m).



ID.TA

Warning board.



IRI.TX4VA

4-channel transmitter with Advanced Rolling Code and Rolling Code.



IRI.TX4AK

4-channel transmitter with Advanced Rolling Code and Fixed Code.



IRI.LAMP

White full range flashing light, 20-255 VAC with built-in aerial.



IRI.KPAD

Battery operated wireless vandal-proof digital keypad with alert buzzer and backlit buttons. Triple coding: Rolling Code, Programmable Code and Advanced Rolling Code. 254 memorisable codes.



IRI.CELL

Pair of vandal-proof metal covers for PUPILLA/PUPILLA.R photocells, comprising front and rear shells with concealed screw. They can maintain perfect orientation over 180°.



PUPILLA

Pair of photocells adjustable to 180°. Option to synchronise up to 4 pairs, 24 VAC/DC power supply. Easy adjustment through a LED that signals optimal alignment. Compact size: 36x110x35 mm

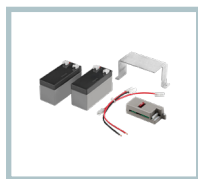

BULL24.CBY

Accessory with CBY.24V battery charger, 1.2 Ah batteries and support bracket.



DA.2S

Electronic board that allows synchronised movement of 2 automation devices (opposed sliding gates).

AUTOMATISMI BENINCÀ SpA • Via del Capitello, 45 • 36066 Sandrigo (VI) ITALY • T +39 0444 751030 • sales@beninca.com

TECHNICAL DATA	BULL624ESA*	BULL624ESA.S*
Power supply	230 Vac (50-60Hz)	230 Vac (50-60Hz)
Motor supply	24 Vdc	24 Vdc
Max absorbed current	0.5 A	0.5 A
Power consumption in stand-by	8 mA	8 mA
Max Thrust	857 N	857 N
Opening speed	5.8÷9.75 m/min	5.8÷9.75 m/min
Duty cycle	intensive use	intensive use
Protection level	IP44	IP44
Magnetic limit switches	NO	YES
Operating temperature	-20°C /+50°C	-20°C /+50°C
Max gate weight	600 kg	600 kg
Driving gear for rack	M4 Z14	M4 Z14
Weight	11.7 kg	11.7 kg
Items no. per pallet	40	40
Kit weight	12.4 kg	---
Kits no. per pallet	40	---

* Available in 115 VAC version